

This program is totally useless...

as far as controlling any process. Now on the other hand if you would like to see how different instructions are converted read on.

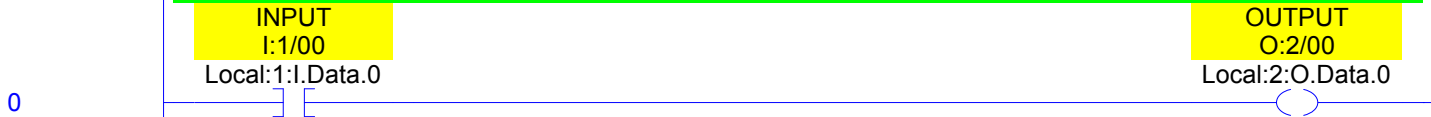

This program was converted using the 1756 option. I/O modules were converted to a local 1756 module in the ControlLogix chassis.
I/O addresses will convert to: Local:SS:I.Data.TT

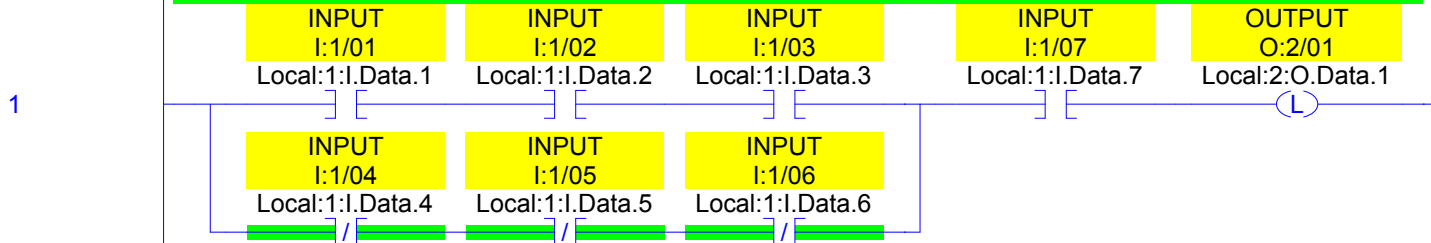

where:
SS = slot
I = Input (or O for Output)
TT = Terminal

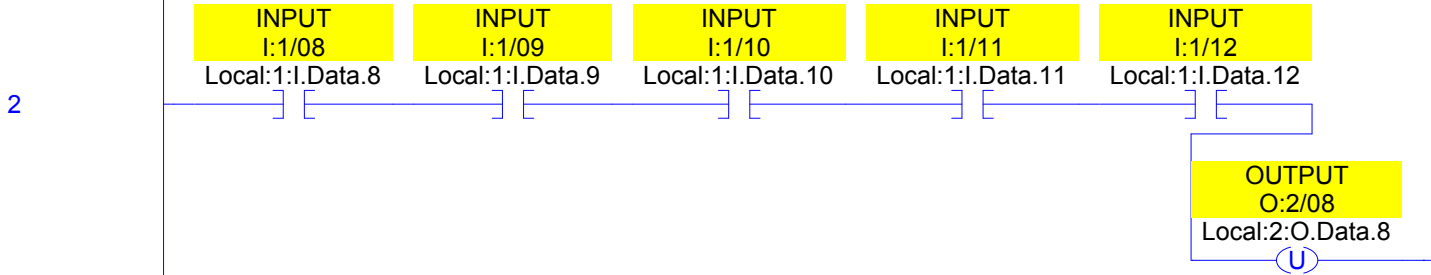

I/O outside of this range (or using the NONE option) or modules that don't convert will point to the INT array (Ixxx or Oxxx).
where: xxx = slot

This section of rungs show how BITS are converted.

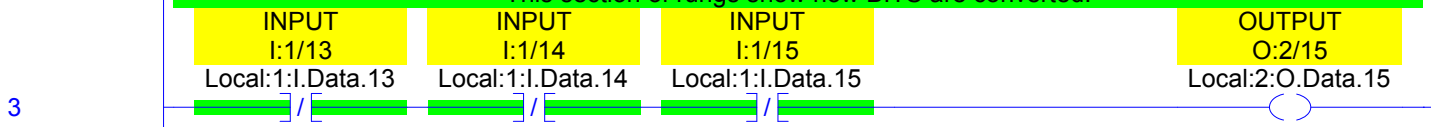

(End)



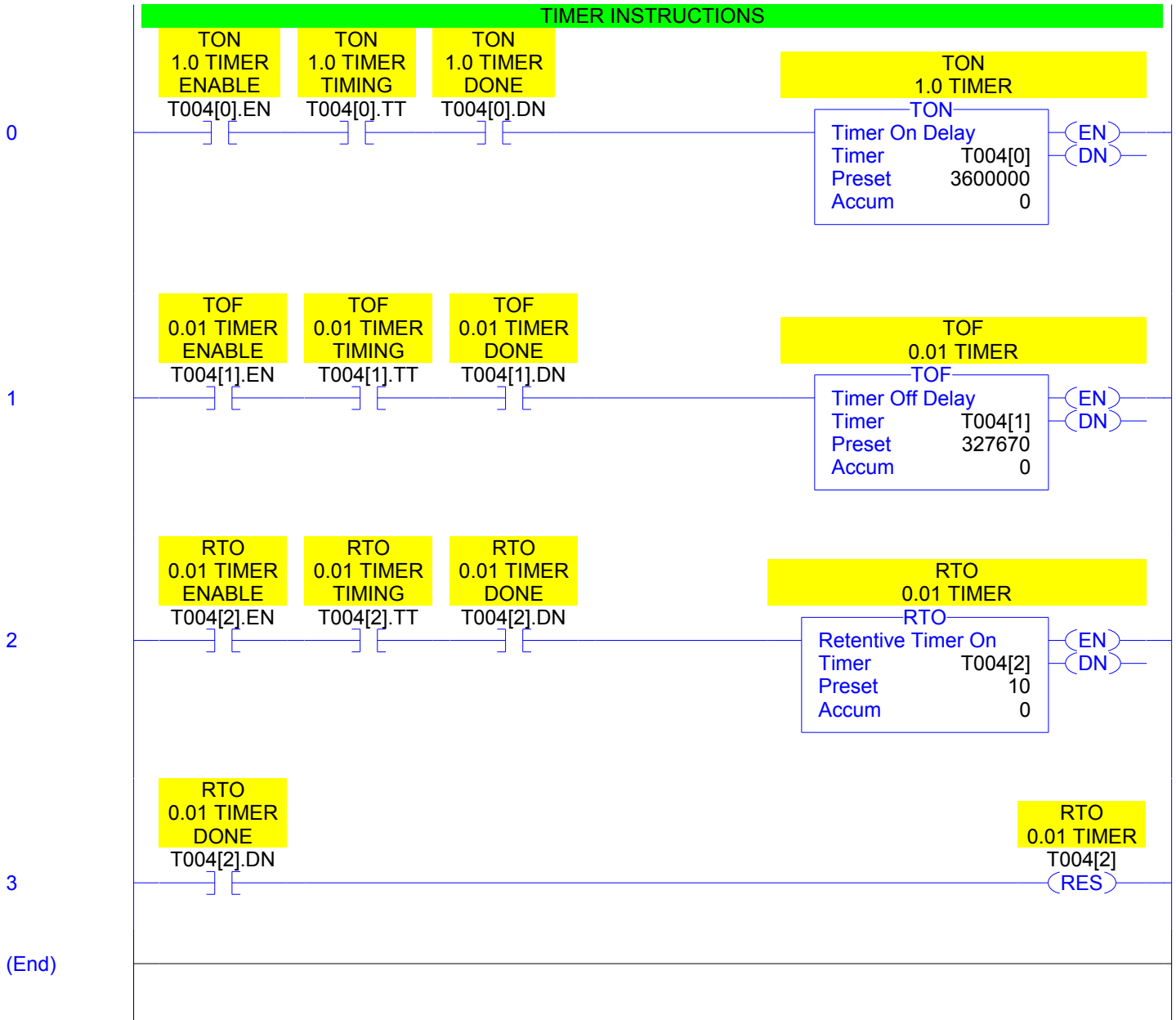

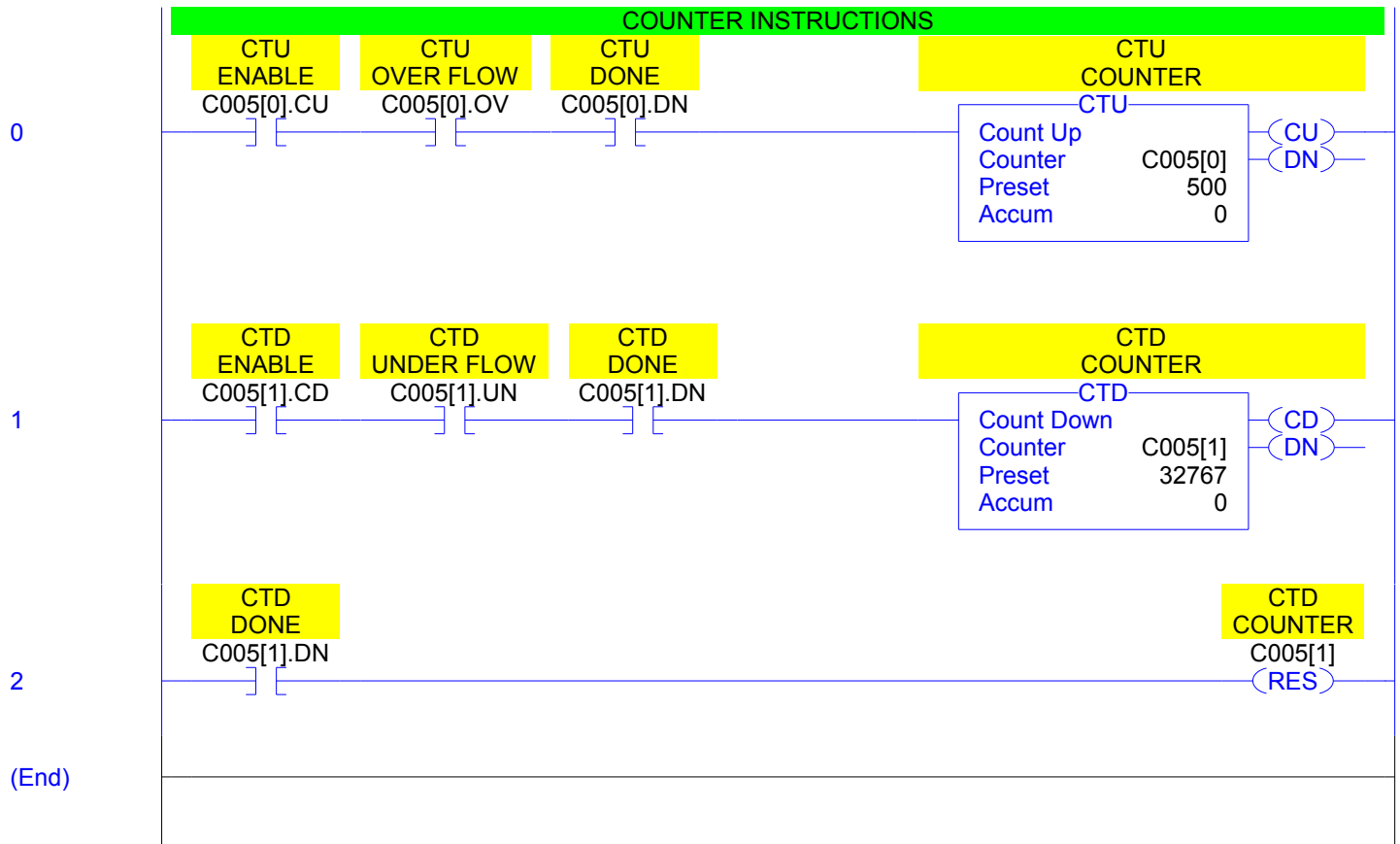

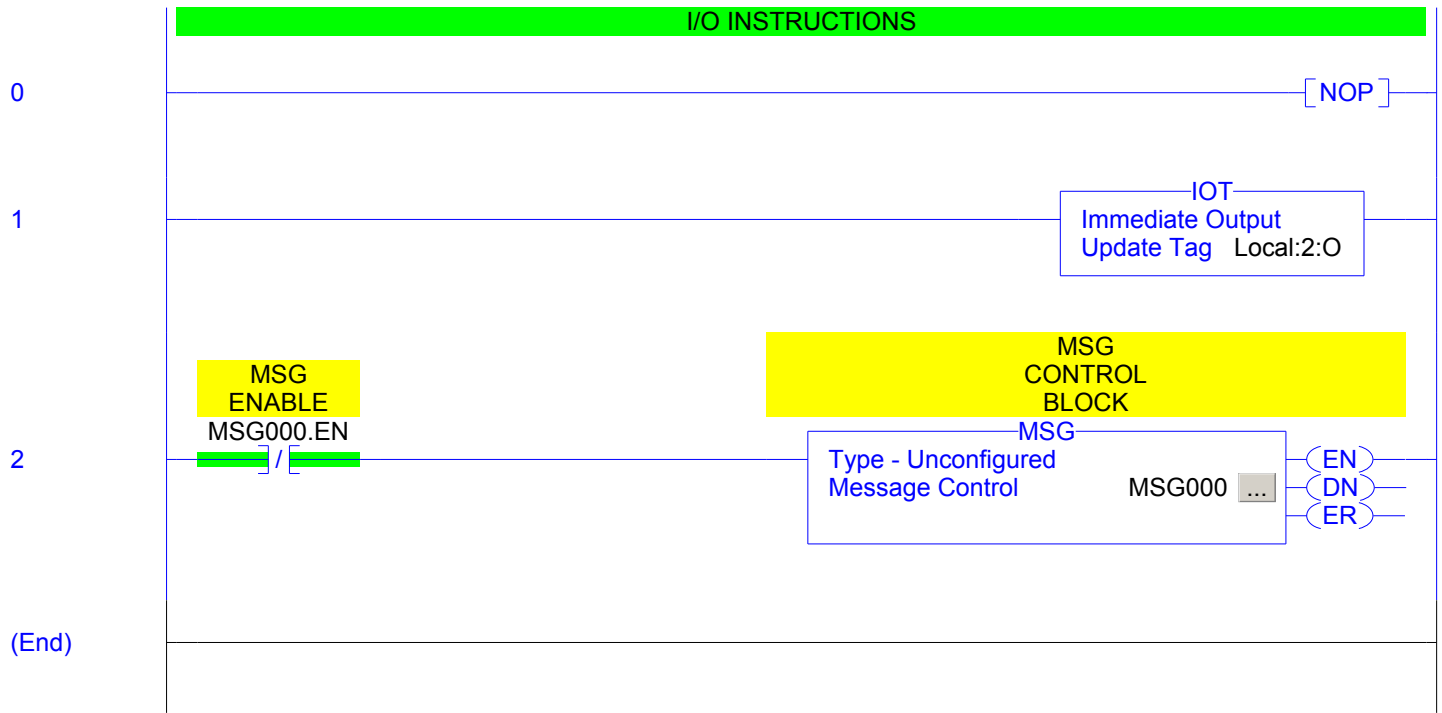

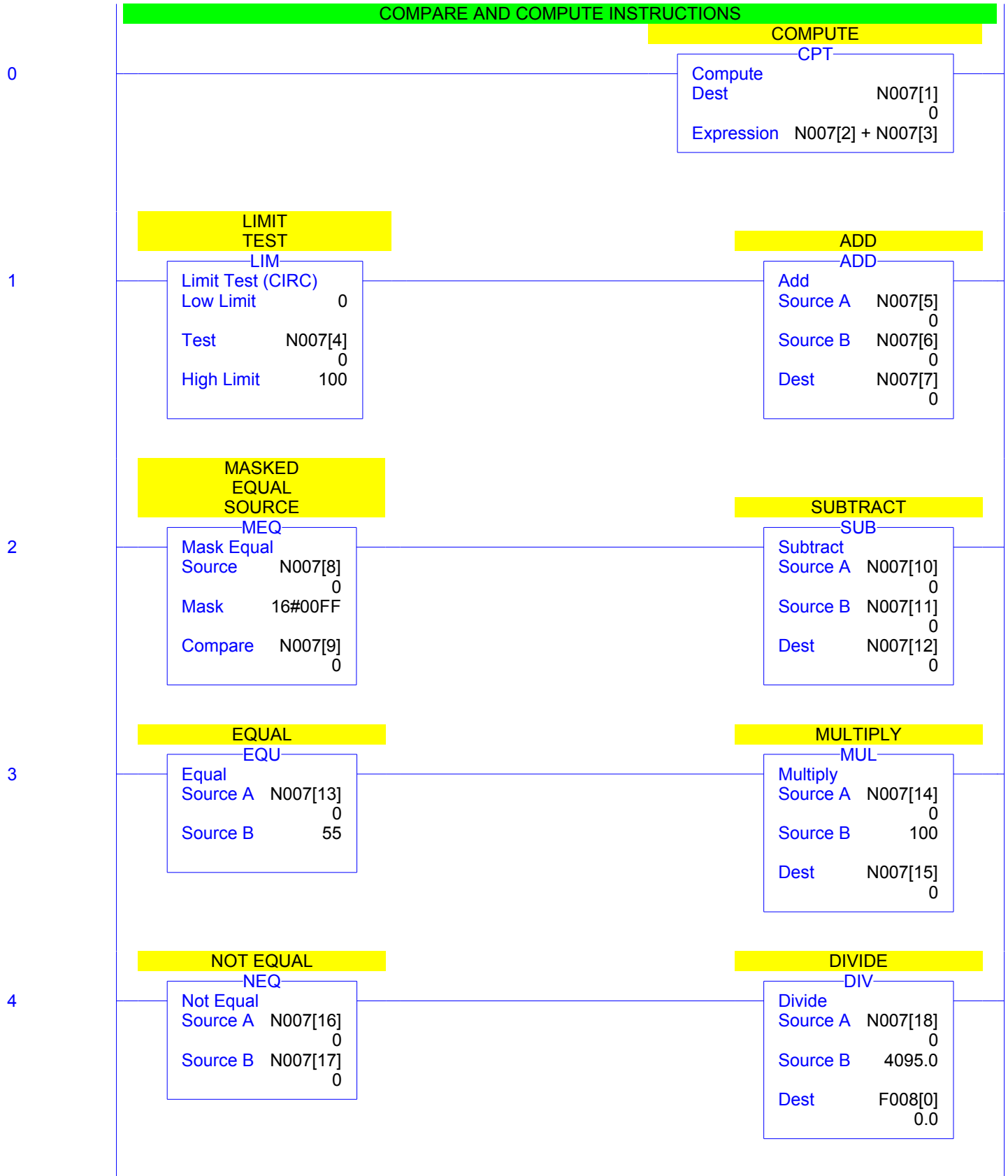

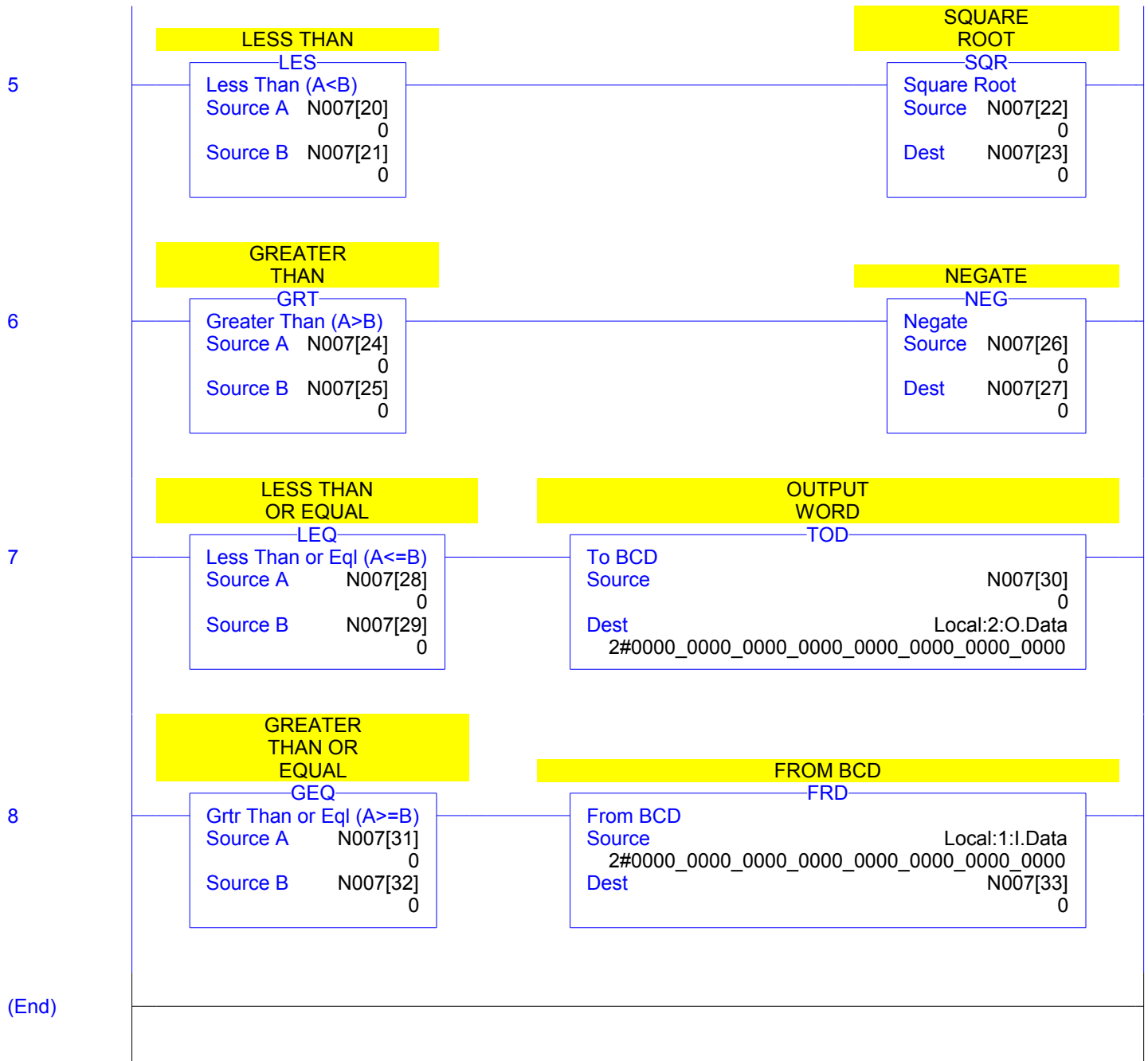

WORD MOVE AND LOGICAL INSTRUCTIONS

0

MOVE
WORD

MOV

Move
Source N011[0]
0
Dest N011[1]
0

1

MASKED
MOVE
WORD

MVM

Masked Move
Source N011[2]
0
Mask 16#0FF00
Dest N011[3]
0

2

BITWISE
AND

AND

Bitwise AND
Source A N011[4]
0
Source B N011[5]
0
Dest N011[6]
0

3

BITWISE
OR

OR

Bitwise Inclusive OR
Source A N011[7]
0
Source B 255
Dest N011[8]
0

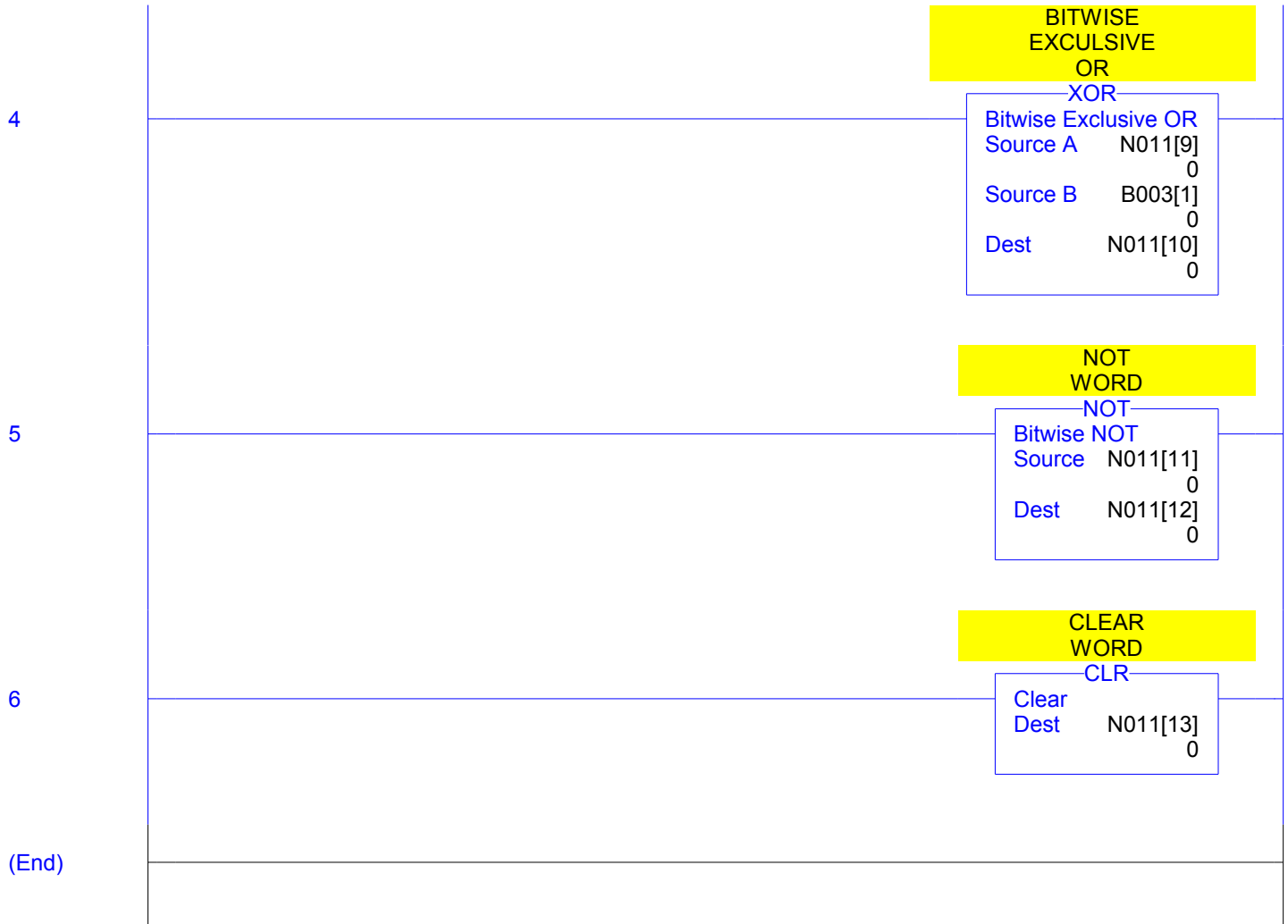

FILE INSTRUCTIONS AND PID

0

COPY
FILE

COP

Copy File	
Source	N012[0]
Dest	N012[10]
Length	10

1

FILL
FILE

FLL

Fill File	
Source	0
Dest	N012[20]
Length	10

2

DOUBLE
DIVIDE

DIV

Divide	
Source A	S000[13]
	0
Source B	N012[30]
	0
Dest	N012[31]
	0

3

SCALE

CPT

Compute	
Dest	N012[33]
	0
Expression	(N012[32] * 1250) + 32

4

PID
ENABLE
BIT
PID000.EN

]/[

PID
CONTROL
BLOCK

PID

Proportional Integral Derivative	
PID	PID000 ...
Process Variable	N012[34]
Tieback	0
Control Variable	N012[35]
PID Master Loop	0
Inhold Bit	0
Inhold Value	0
Setpoint	0.0
Process Variable	0.0
Output %	0.0

(End)

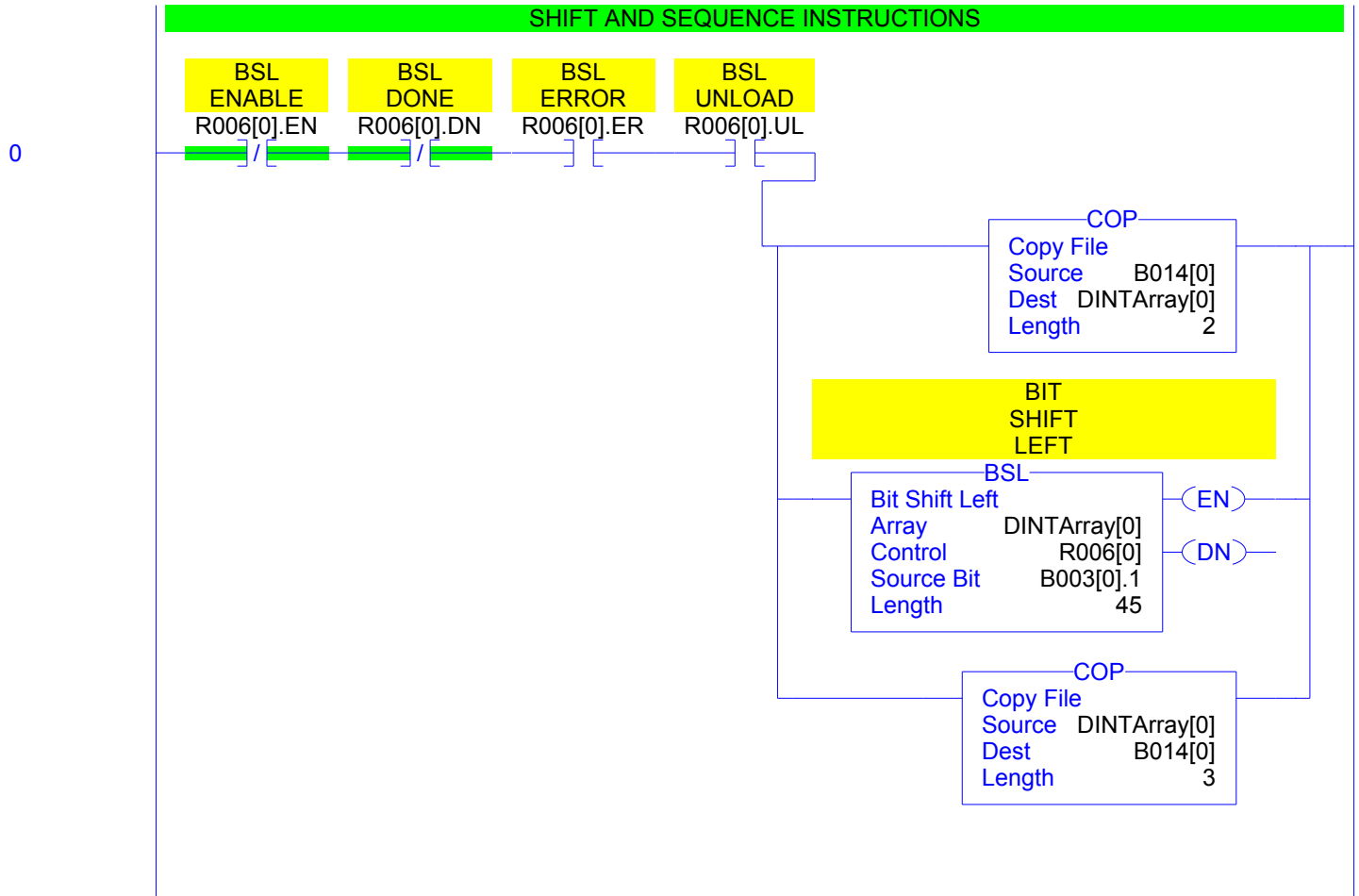

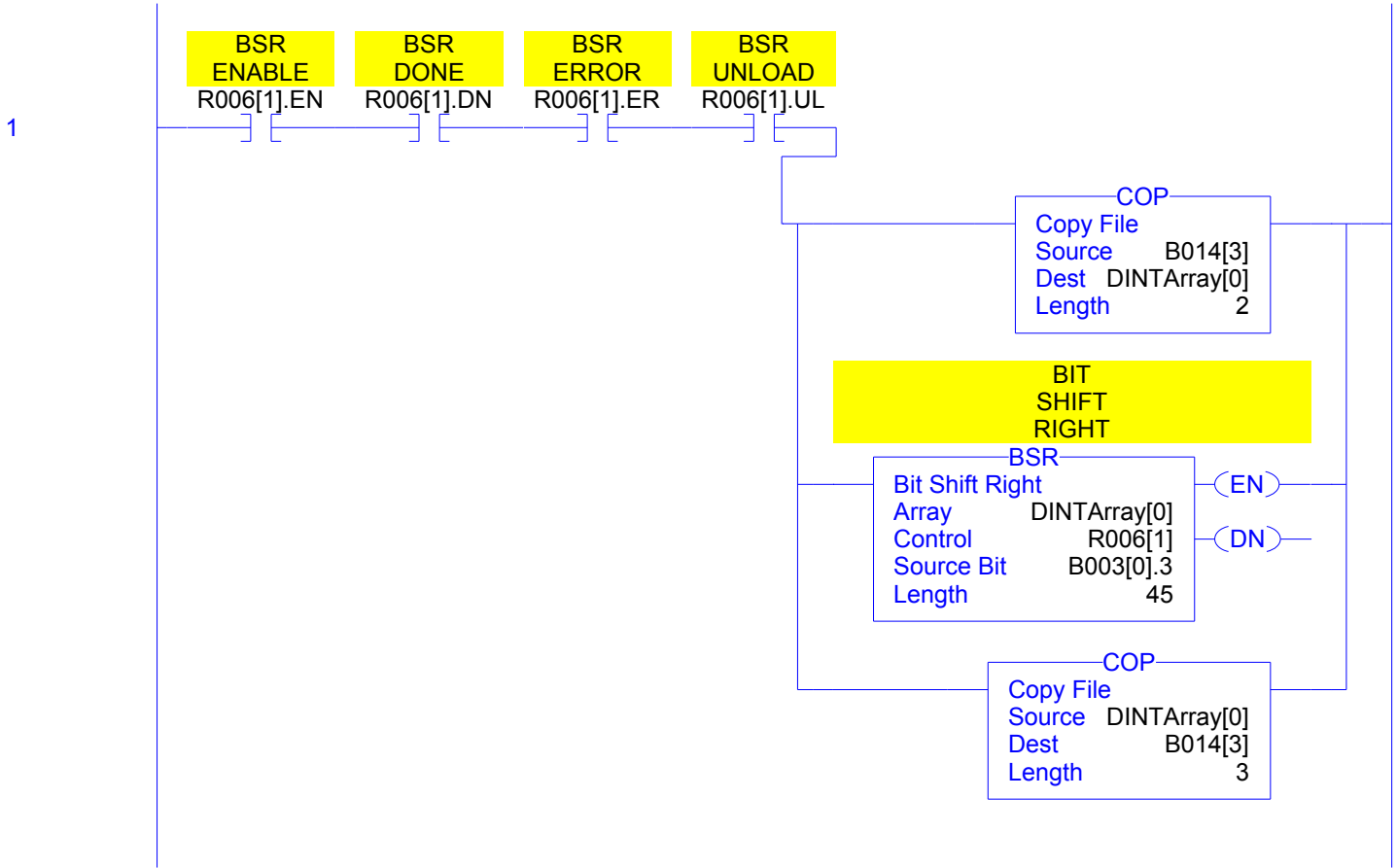

2

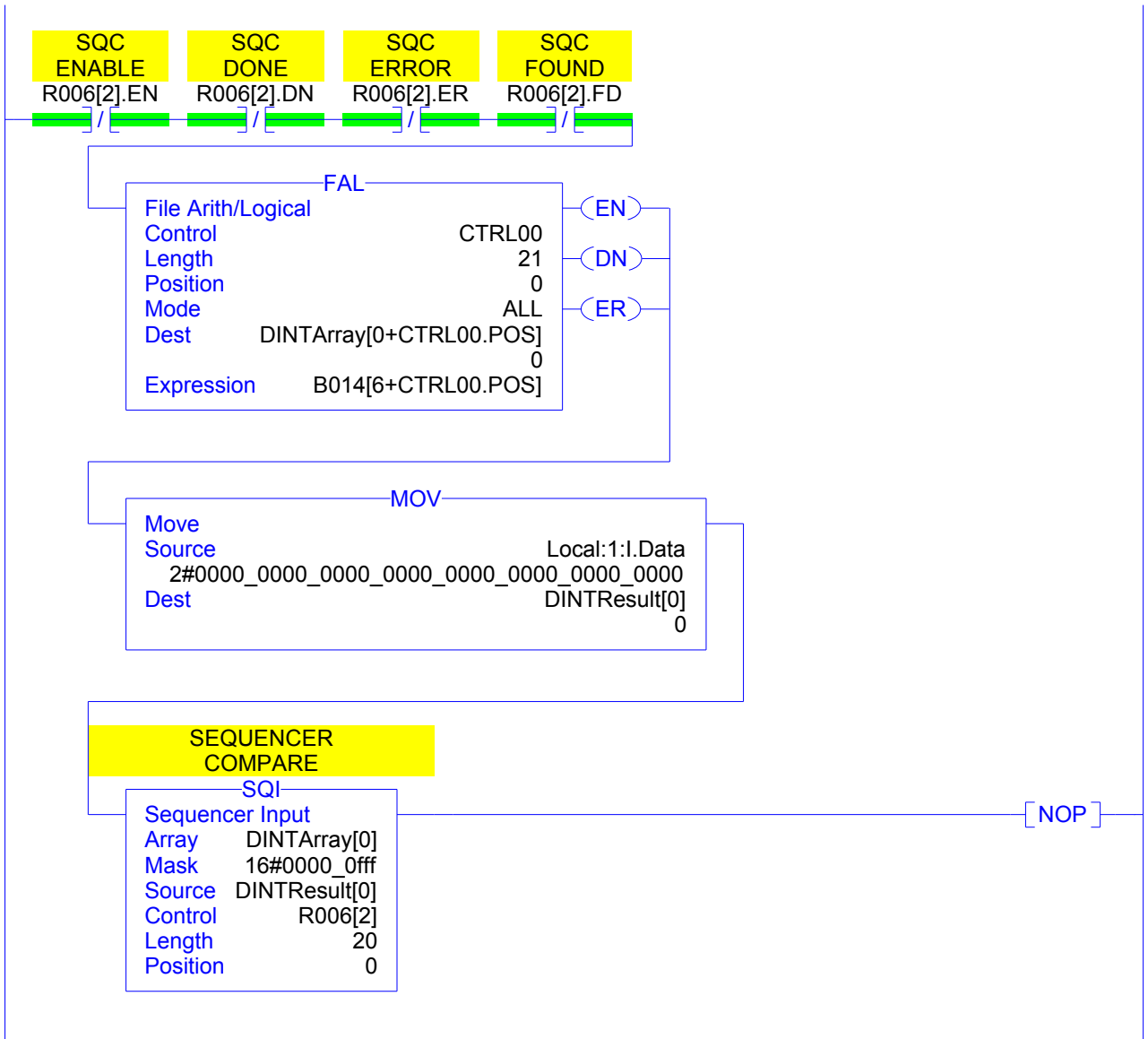

3

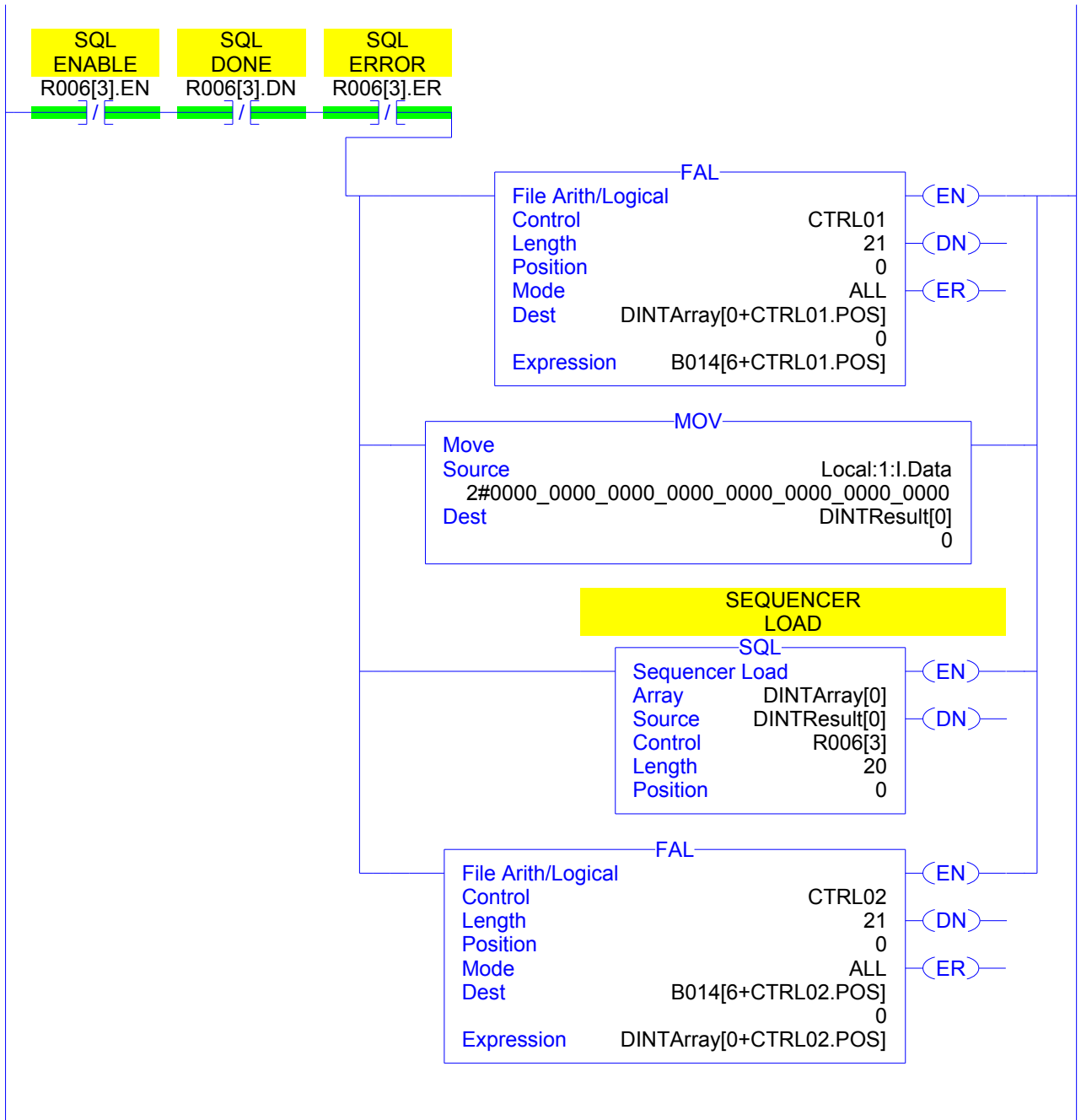

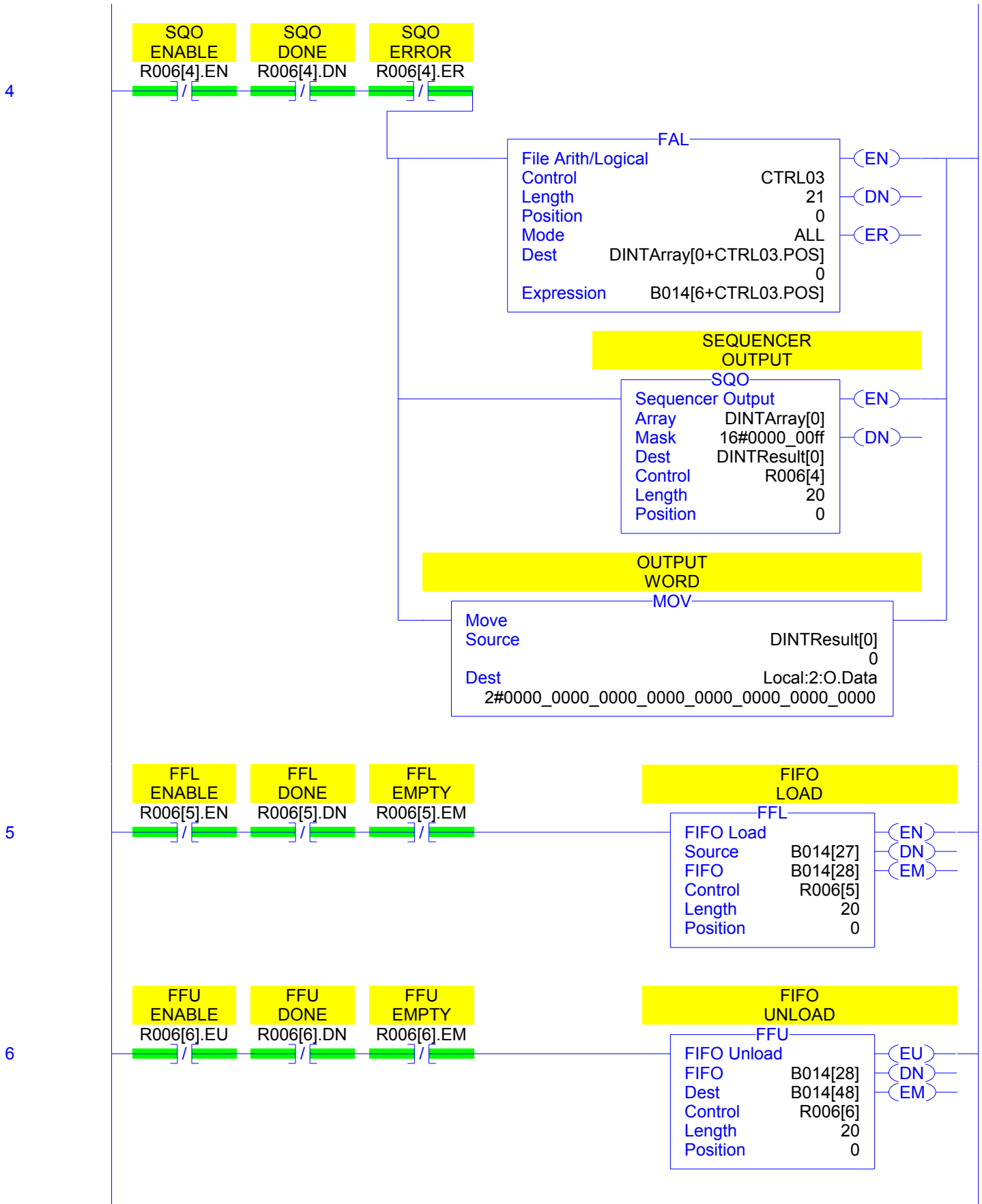

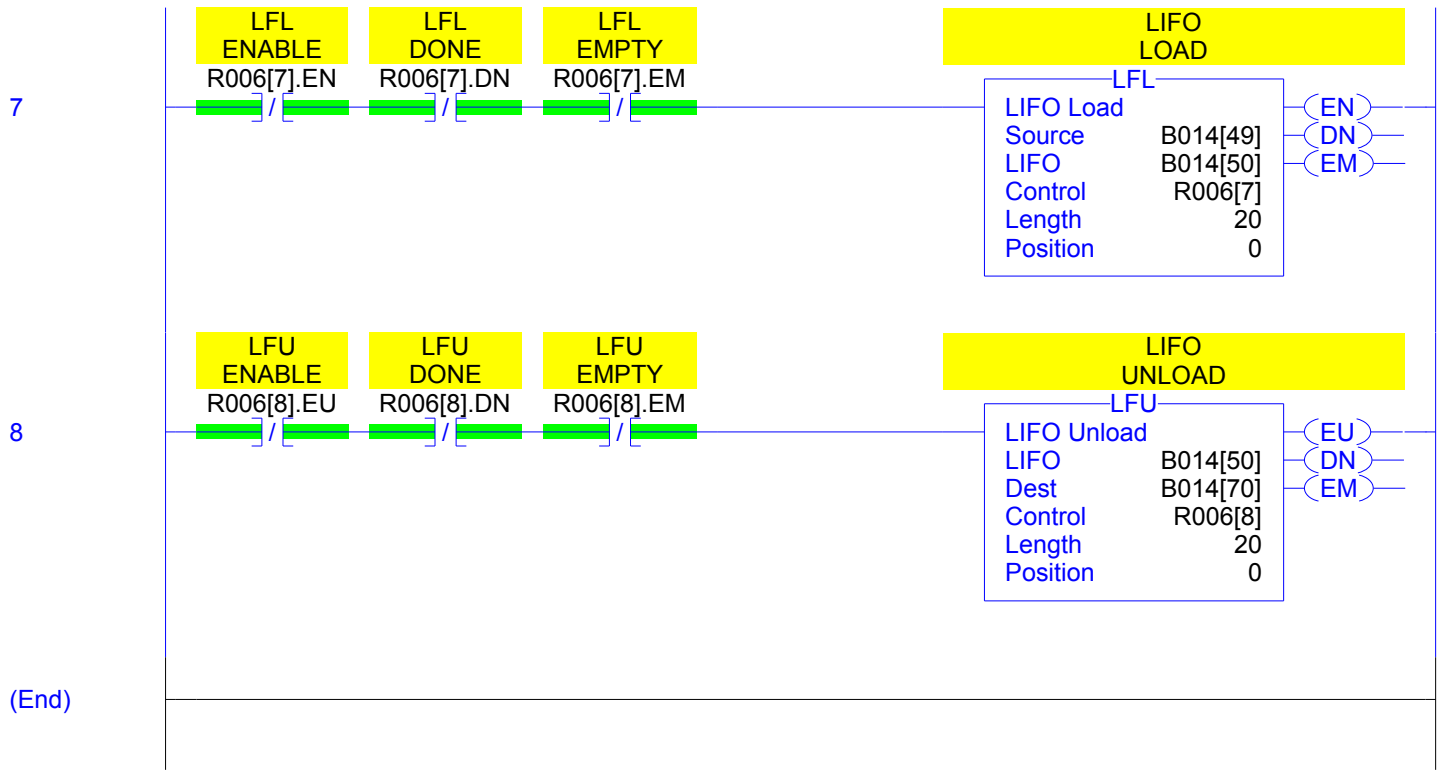

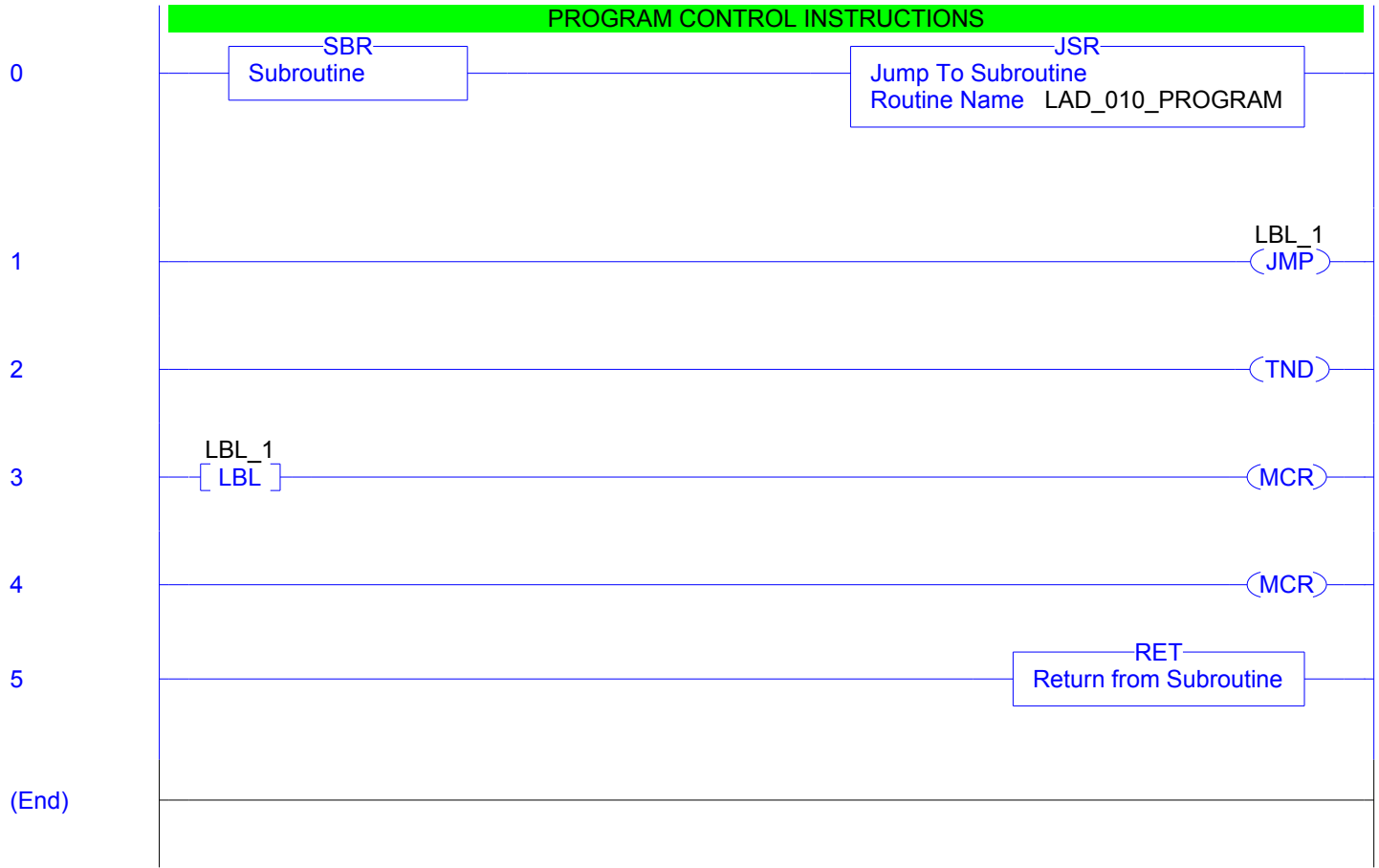

ADVANCED MATH INSTRUCTIONS

SINE

SIN

Sine
Source F015[0]
0.0
Dest F015[1]
0.0

COSINE

COS

Cosine
Source F015[2]
0.0
Dest F015[3]
0.0

TANGENT

TAN

Tangent
Source F015[4]
0.0
Dest F015[5]
0.0

ARCSINE

ASN

Arc Sine
Source F015[6]
0.0
Dest F015[7]
0.0

ARCCOSINE

ACS

Arc Cosine
Source F015[8]
0.0
Dest F015[9]
0.0

ARCTANGENT

ATN

Arc Tangent
Source F015[10]
0.0
Dest F015[11]
0.0

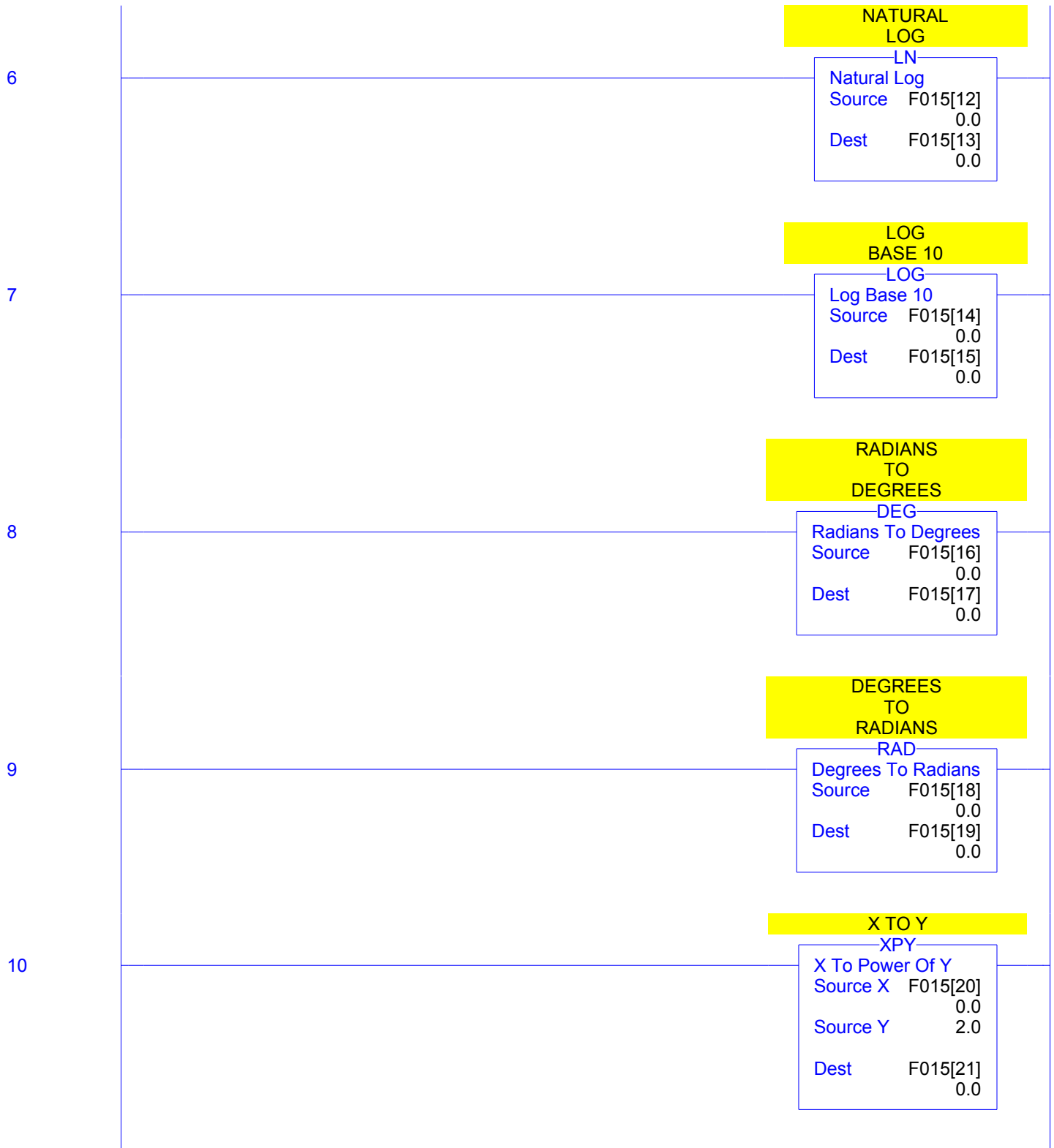

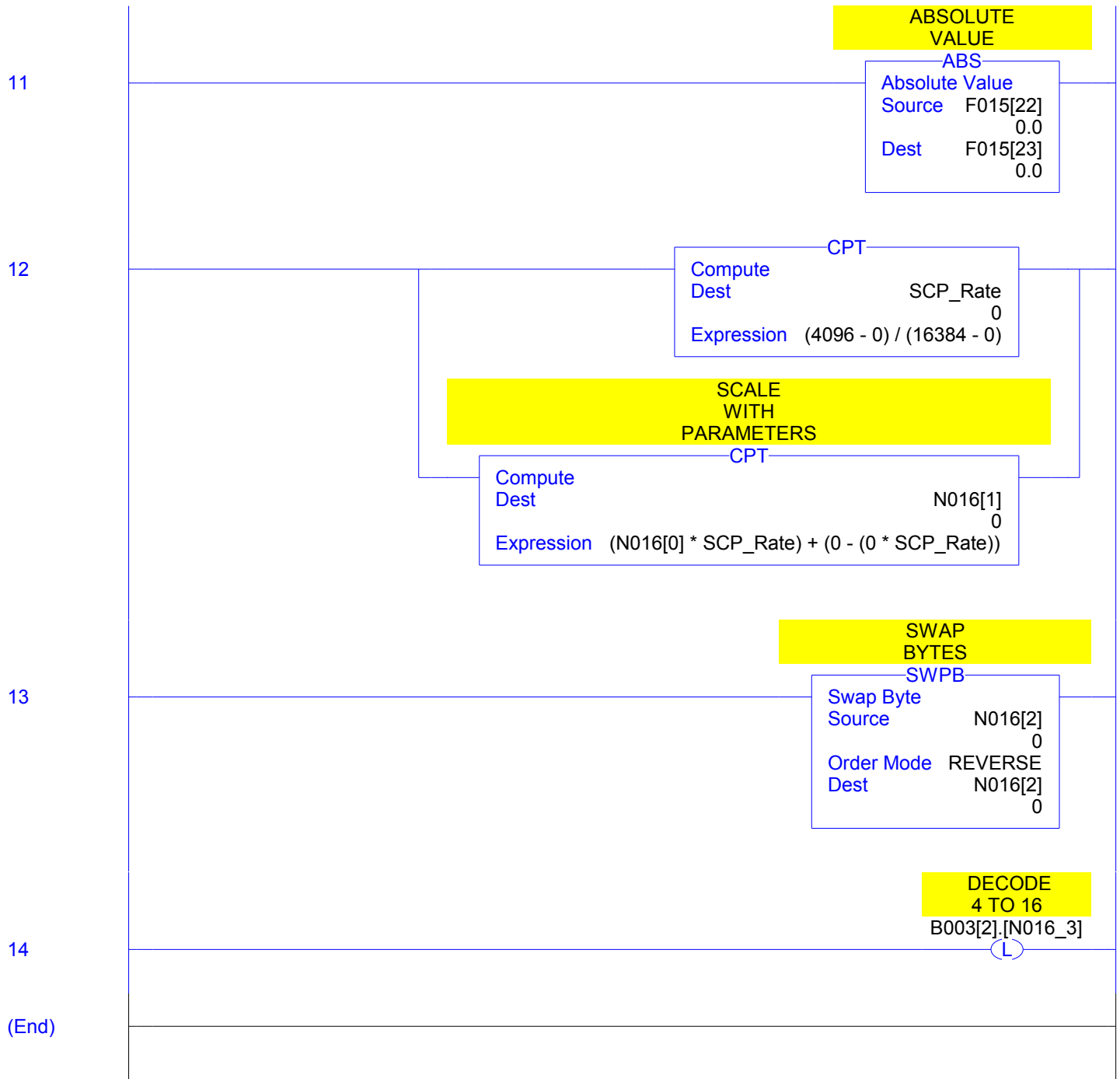

INDIRECT ADDRESSING

These rungs show how indirect addresses will be converted. Indirect addresses can not be documented in the ControlLogix.

POINTER ADDRESS

0

MOV

Move
Source 1
Dest N017_0
<N017[0]>
0

1

N007[19].[N017_0]

MOV

Move
Source 2
Dest N007[N017_0]
0

(End)